

For Hydraulic Elevators

The Blain Micro Drive for hydraulic elevators consists of a small motor, pump and valve unit in one assembly. Exact floor stops and releveling operations are achieved with low electrical power requirement, low noise levels and no unnecessary heating of the oil. The MD unit is mounted on or under the cover of the main hydraulic power unit, using the same oil source. It can also be used to slowly move the car independently of the main drive during installation or in an emergency.

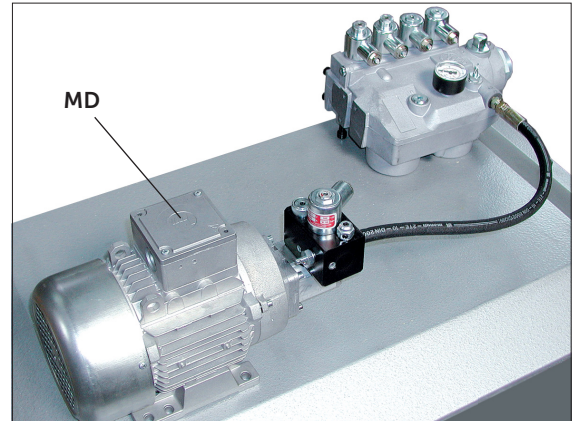
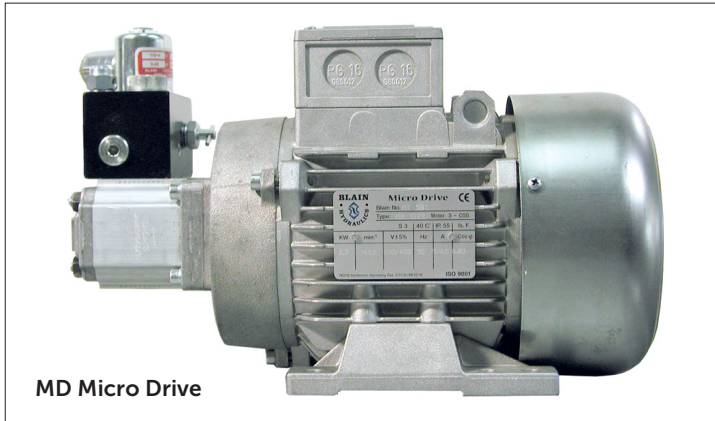

For Traction Elevators

The Micro Drive is equally effective as a separate unit for accurate releveling of traction elevators, where a small cylinder is integrated into the cable suspension. This eliminates the need to start the main drive when the car needs to be moved only a few centimetres.

Micro Levelling Speeds

Micro levelling at approximately 1 cm/sec (2 ft./min.) is recommended at which speed positioning of the car is highly accurate and the releveling movement, usually lasting less than a second, is barely if at all noticeable by the passenger. Floor stopping accuracy of better than plus-minus 5 mm (0.2 inch) can be expected, provided the floor switch system is correspondingly accurate. Outside of 2 cm (0.8 inch) from the floor landing, the main elevator releveling system must be activated.

Increased safety

Exact landing of the car eliminates the danger of passengers tripping while entering or leaving the car.

Faster Floor to Floor Times

Because the Micro Drive assures final stopping accuracy, the main levelling approach speed to the floor can be increased to approximately 10 cm/sec (20 ft/min) to shorten travelling time.

Quicker Releveling

When a load is added to or removed from the car causing it to shift its position, the MD Unit releveling correction begins instantaneously and usually taking less than one second to complete. There is no unwanted delay due to bypassing of oil as it is the case with the main hydraulic drive.

Quieter Releveling

Since the main power unit does not need to be started, releveling with the Micro Drive unit is quiet and shorter in duration than when employing the main hydraulic drive. This is especially important in private homes or offices, where the releveling sound of the main elevator drive can be disturbing; especially at night-time.

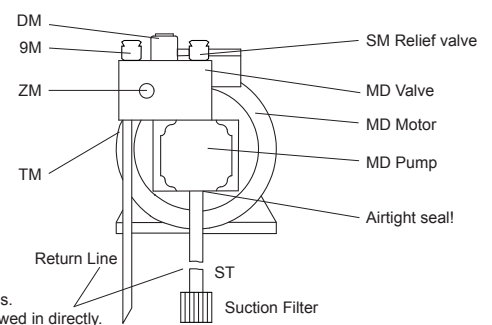
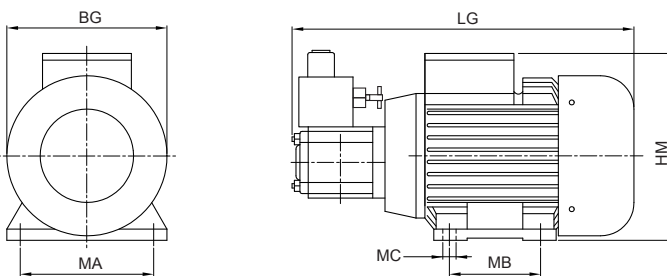

TM & ST: Do not use hydr. fittings. Use only low pressure pipe screwed in directly.

Measurements

Type	lpm 50 Hz	gpm 60 Hz	KW	max bar	max. psi	Ports			LG mm	BG mm	HM mm	MA mm	MB mm	MC mm	weight	
						ST Suction	TM Tank	ZMCylinder							kg	lbs
MD 0103	1.0	0.3	0.37	130	1870	1/4"	3/8"	3/8"	220	120	175	100	80	7	6	13.5
MD 0205	1.9	0.6	0.55	130	1870	3/8"	3/8"	3/8"	290	140	190	110	90	7	8.5	19
MD 0411	4.2	1.3	1.10	130	1870	3/8"	3/8"	3/8"	325	160	200	120	100	10	10	22
MD 0611	6.4	2.0	1.10	130	1870	3/8"	3/8"	3/8"	330	160	200	120	100	10	10.5	23
MD 1022	10.6	3.3	2.20	130	1870	1/2"	3/8"	3/8"	355	175	215	140	125	10	16	35.5
MD 1535	15.4	4.8	3.50	130	1870	1/2"	3/8"	3/8"	410	195	245	160	140	12	25	55
MD 2450	24.0	7.5	5.00	130	1870	3/4"	3/8"	3/8"	450	220	265	190	140	14	32.5	72

US units

mm ÷ 25.4 = inches

Blain Hydraulics GmbH
 Pfaffenstrasse 1
 74078 Heilbronn
 Germany
 Tel. 07131 2821-0
 Fax 07131 2821-99
 www.blain.de
 info@blain.de



GmbH

Manufacturer of the Highest Quality:
 Control Valves for Elevators
 Tank Heaters - Hand Pumps
 Pipe Rupture Valves - Ball Valves



Hydraulic Circuit

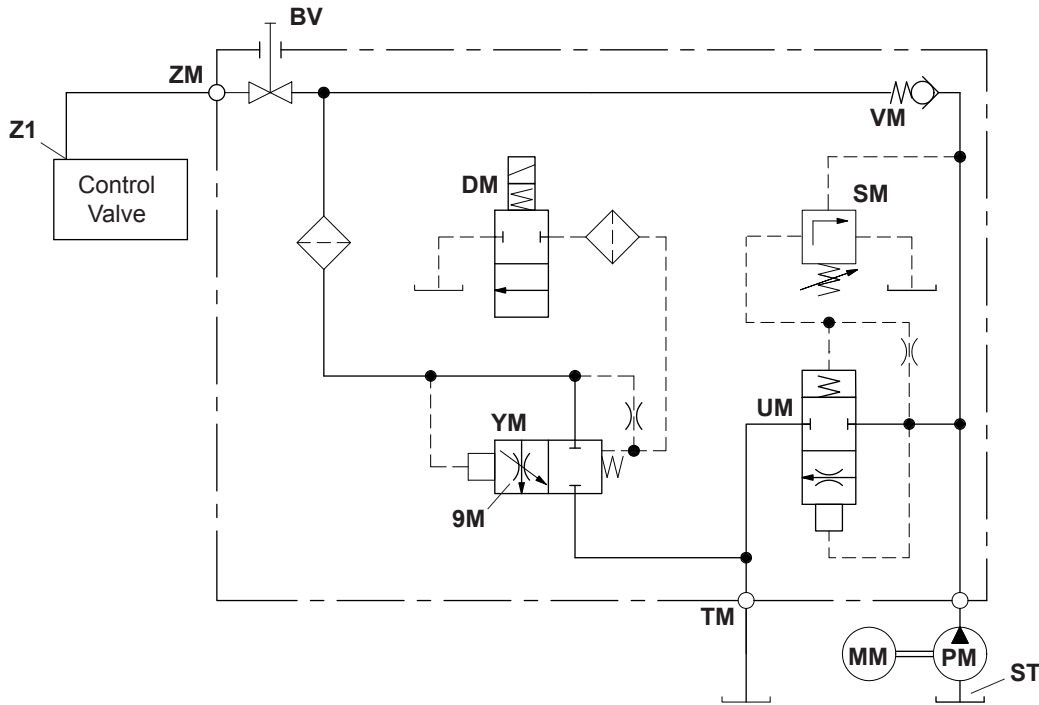

- | | | | | | |
|-----------|----------------------------------|-----------|---------------------|-----------|-----------------------------|
| DM | Solenoid Down | BV | Shut Off Valve | PM | MD-Pump |
| 9M | Down Speed Adjustment | ST | Suction Tube | UM | Pilot Operated Relief Valve |
| SM | Pressure Relief Valve Adjustment | ZM | Cylinder Connection | YM | Pilot Operated Down Valve |
| VM | Check Valve | TM | Return Connection | | |
| | | MM | MD-Motor | | |

Selection Chart

50 Hz Motors (For 60 Hz connection, add 20% to pump flow rates and MD levelling speeds)

Example:

Ram
127 mm
5"

Pump
6.4 lpm
1.7 gpm

Speed
~0.84 cm/sec
~5/16 "/sec

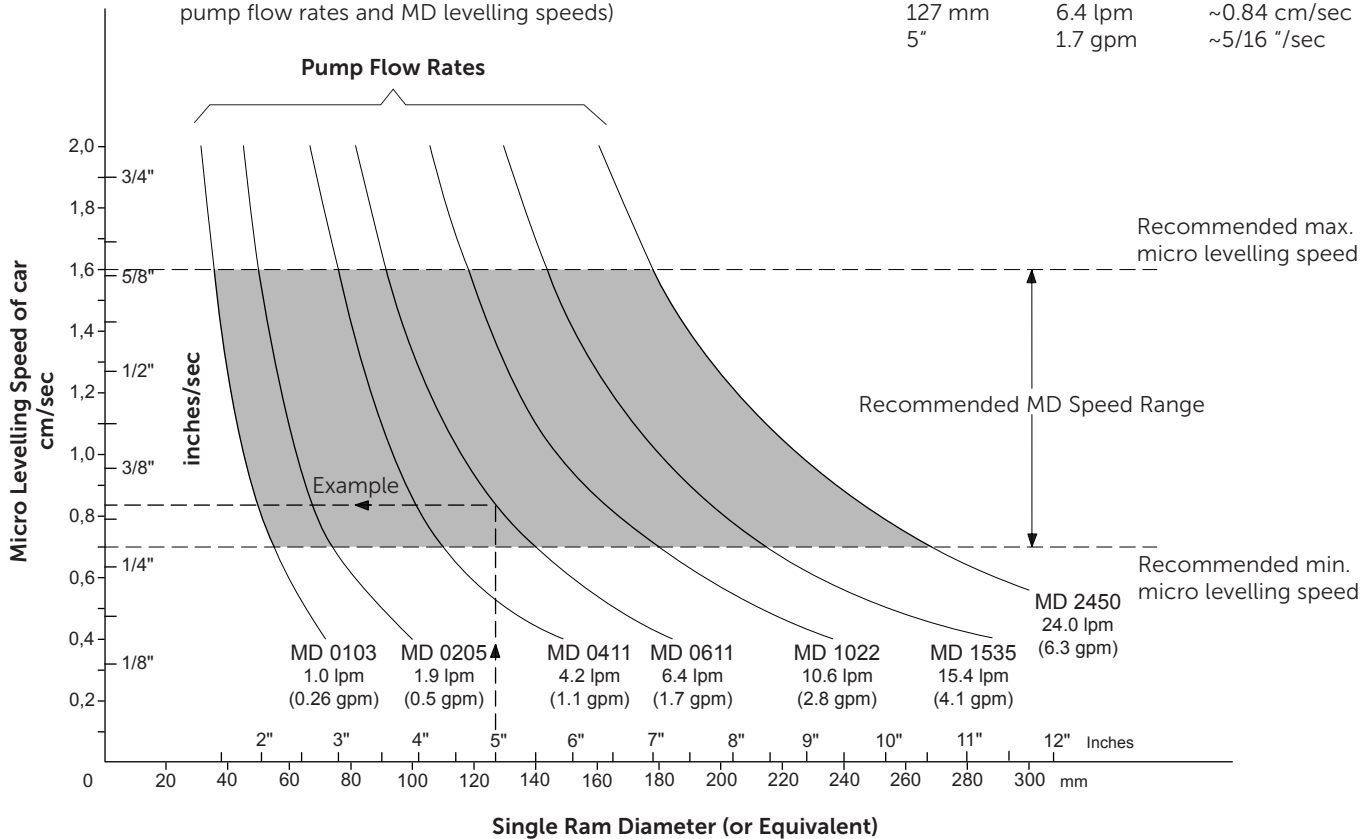

The Equivalent Ram Diameter is the calculated single ram diameter which would produce the same car speed as the alternative cylinder system.

Electrical Sequence

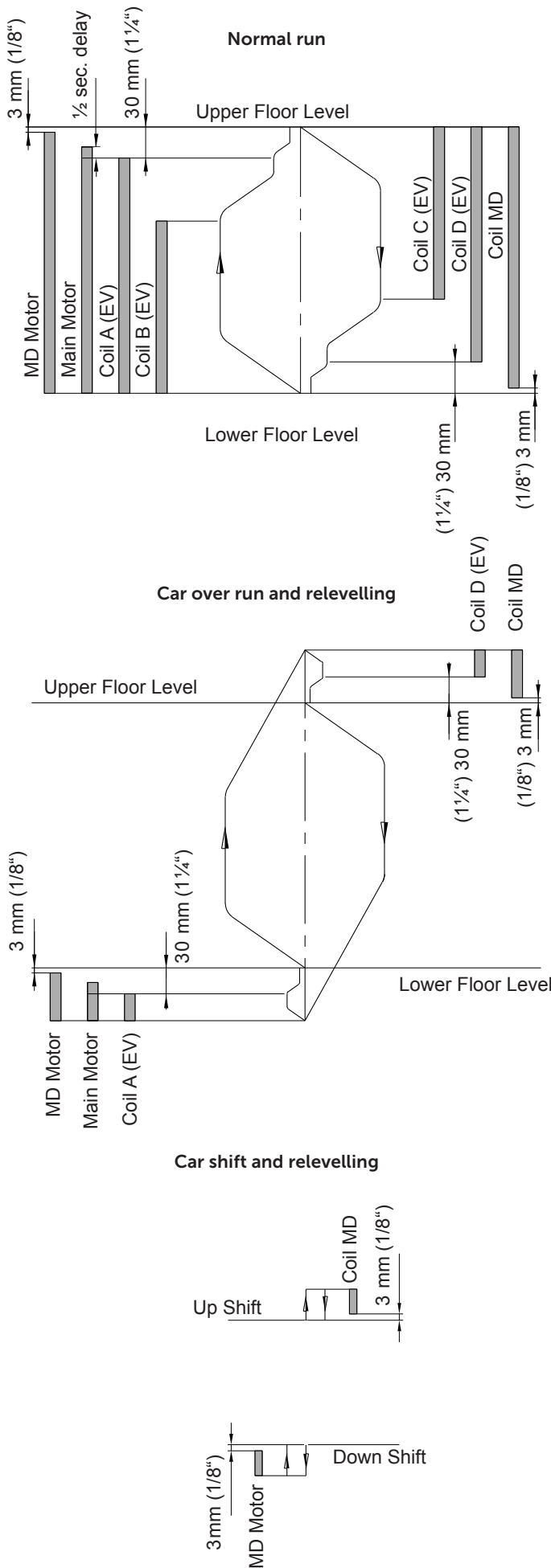

Normal Run

1. At the beginning of a normal up run, the friction of the system (stiction) is overcome by the Micro Drive. This reduces any breakaway jerk.
2. The standard control valve levelling speed no longer determines the stopping accuracy of the elevator. Therefore it can be increased to approximately 10 cm/sec. (20 ft/min), effectively smoothing out the ride and at the same time, shortening the floor to floor travelling time.
3. The stopping accuracy of the car, determined by the Micro Drive, is improved to less than 5 mm (0,2 inch) from floor level.

Over Run

If the car travels past the floor level, the shaftway switches would activate to re-level the car through the MD unit, in less time than it takes the car doors to open and more accurately than with the standard levelling system. Should the MD correction not be completed within 2-3 seconds, the main levelling system automatically actuates.

Car Shift

When the position of the car shifts away from floor level due to loading or unloading, cooling of the oil or valve leakage, the Micro Drive performs a releveling correction when the shift exceeds 3 mm.



Important

An accurate levelling switch installation is a precondition for satisfactory results.



Installation and Parts List

Warning: Only qualified personnel should adjust or service valves. Unauthorised manipulation may result in injury, loss of life or damage to equipment. Prior to servicing internal parts, ensure that the electrical power is switched off and residual pressure in the valve is reduced to zero.

MD Installation

1. Use the same oil reservoir for the **MD** unit as for the main pump drive.
2. Do not use hydraulic fittings for suction and return lines. Their smaller bores, prevent efficient oil flow. For the suction line, use low pressure, taper threaded tube, screwed directly into the suction port **ST** of the pump with airtight sealing and with the lower end including filter, submerged at **all times** under the reservoir oil level. To avoid sucking air, ensure that the thread connection into the pump is perfectly sealed, for example with teflon tape.
3. For the return line to tank, also use low pressure, taper threaded tube, screwed directly into the tank port **TM** of the valve.
4. For the cylinder line connection, high pressure hose may be used to join port **ZM** of the valve to the main cylinder line.

Electrical Installation

5. The existing safe operation of the elevator according to the applicable local code, must not be changed. Separate **MD** relevelling switches set to trigger **MD** relevelling at between 2.5 to 5 mm (0.1 - 0.2 inches) above and below flow level which are actuated before the main relevelling switches.
6. Electrical connections are 3 phase direct starting.

MD Adjustments

Up Speed is determined by the pump output and the effective diameter of the cylinder system.

SM Relief Valve. 'In' (clockwise) produces a higher, 'out' (c-clockwise) a lower maximum pressure setting.

9M Down Speed (Micro Drives MD1022 and 2450). When solenoid **DM** is energised, the car will travel downwards at a speed according to the setting of adjustment **9M**, (3mm socket key). Turning 'in' (clockwise) provides a slower, turning 'out' (c-clockwise), a faster down speed.

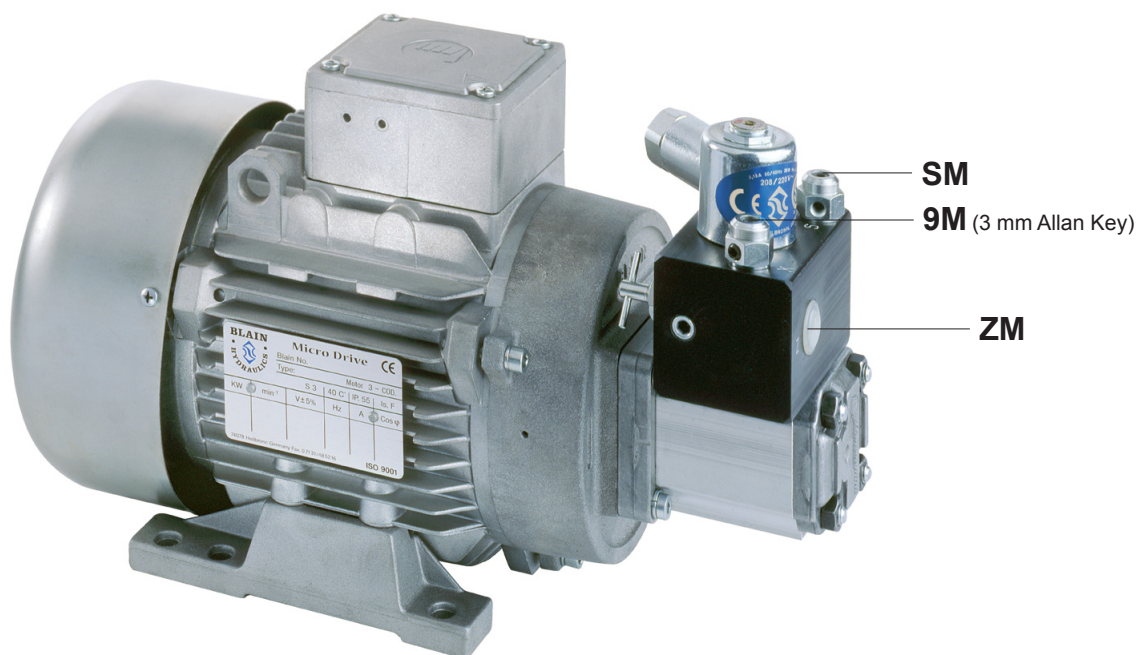

Micro Drive Unit
(1,0 to 24 lpm) (0,3 to 7,5 gpm)